

System 250 Data Sheet



The new BOFA system 250 is a compact high volume unit designed to extract fumes through a variety of extraction accessories. The system comes complete with a user friendly installation kit allowing instant extraction for minimum fuss and cost.

Carcass

Main body, central support, lid and base are powder coated Zintac

Standard Equipment

- Weight: 10kg
- Filter Indication light
- Noise level: below 55dba
- Integral silencer with air exhausted out the base of unit
- Standard Filter set (see below)
- 2 x 50mm Diameter inlet
- Thermal trip
- System 250 Installation Kit (table brackets, Flip-Top connectors, mounting plates, adaptors with balancing valves & flexi tubing)

Electrics

- 230v 1ph 50hz or 110v 1ph 60hz
- 2m Power Cord
- Fused IEC illuminated switch
- Full load current: 1.5 amps

Warranty

- 12 month warranty
- 12 month COSHH Certification (when installed by BOFA engineers)

Standard Filter Set

Pre Filter
95% efficiency @ 0.8micron

Combined Filter
HEPA 99.997% @ 0.3 micron
Gas Filter media
Activated carbon impregnated with potassium permanganate

Maximum number of arms

32mm	50mm	75mm
EC: 4	EC: 2	EC: 1
US: 4	US: 2	EC: 1

Blower / Pump

- Radial Ventilator
- 40,000 life hours
- Pressure 40m/bar
- 0.12k Output
- Airflow 180m³/hr (with filters fitted)
- IP54 Synchronous (brushless) motor

Options

VOC Monitoring

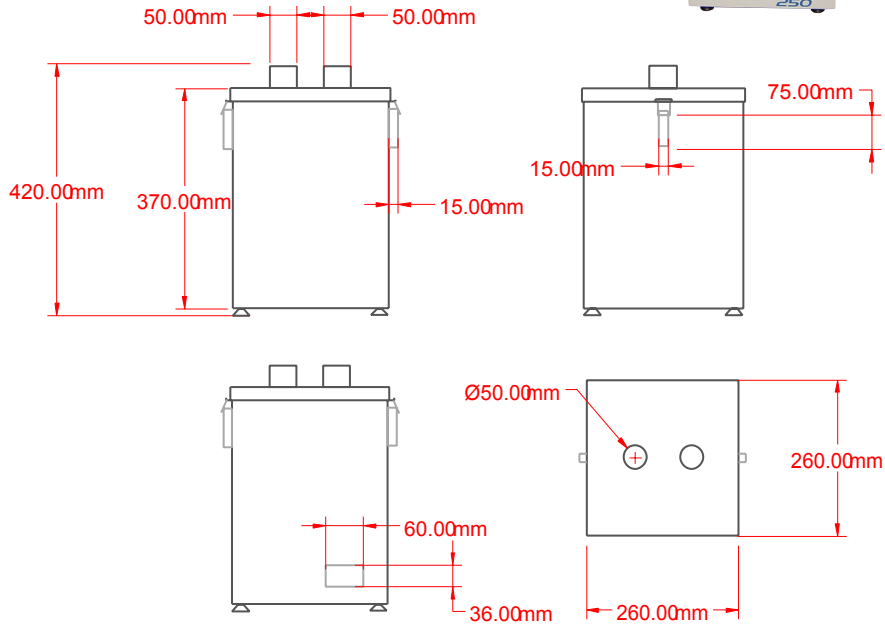

The system 250 comes complete with the installation kit shown opposite x 2. This includes 3 meters of 50mm flexible tubing, 2 x table brackets & mounting plates, 2 x flush system seal Flip top connector and adaptor with balancing valve.

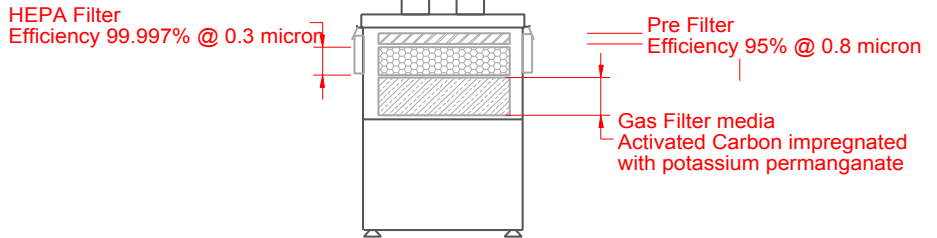

The chart opposite shows the maximum number of soldering arms that the System 250 is capable of extracting from.

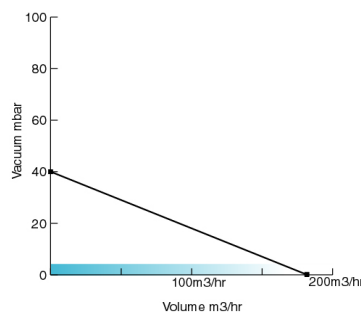
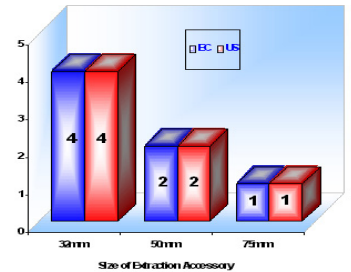

The chart opposite shows the performance of the pump within the System 250. The performance curve also highlights the effect of new filters on the new System 250's vacuum capabilities