

SHARP ZENIGATA CHIP ON BOARD



Sensational Light, Simplified Design.

Sharp Zenigata Chip on Board technology leverages a uniform Light Emitting Surface (LES) to make optical design easier, improve light quality, and allow you to create more elegant products. A unique, fully insulating ceramic substrate provides optimal heat dissipation and low color shift, with even lumen output over time.

Now, choose from Sharp LEDs ranging from 0.2W – 80W, including Zenigata COB LEDs and Sharp's specialty Double Dome product line. New Mega Zenigata modules deliver up to a 400W equivalent of incandescent light. In addition to big energy savings, these powerful LEDs eliminate the sub-standard design aesthetic and uneven light quality that results from the use of multiple low-power LEDs in a luminaire.

Zenigata LEDs deliver high efficacy (high performance modules exceed 100 lm/W) and typical* hot lumen performance is greater than 90%. Each Zenigata product family features a uniform package size and a typical operating life exceeding 50,000 hours.

**See Product Specifications*

The Color of Life

Life happens in full spectrum. Lighting products need to be more than just functional and reliable; they must also accurately illuminate the dazzling colors that shape our world, and make objects, people, and places look their absolute best.

Sharp LEDs bring you some of the richest, most true-to-life color rendering available. Products in our Mega Zenigata High CRI line boast color rendering up to 93 CRI, and all Sharp LEDs meet or exceed the ENERGY STAR® minimum requirement of 80 CRI. Still, we recognize that CRI measurement alone is not enough.

Sharp incorporates a blue LED die with a proprietary mixture of green and red phosphors to go beyond typical CRI measurements (R1 – R8) with powerful performance up to R15. This includes excellent R9 (deep red) rendering. Accurate, deep reds lend a warm, vibrant aesthetic that will help elevate your lighting products from “efficient” to “unforgettable.”

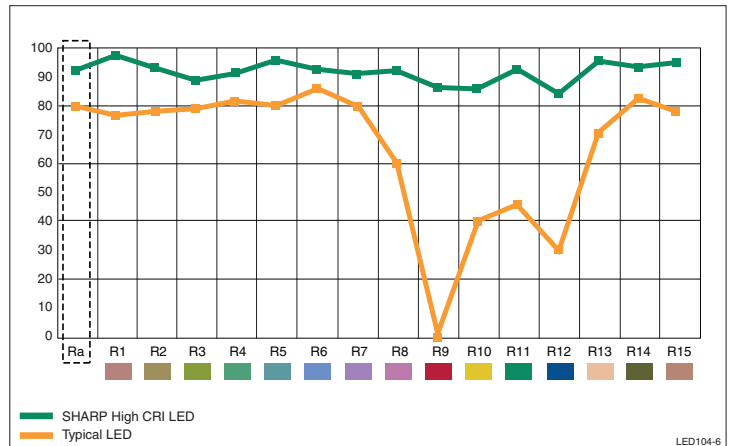

The Mega Zenigata COB

The Mega Zenigata COB family provides a powerful, energy-saving LED alternative for incandescent, halogen, and compact fluorescent applications. Use just one LED in a fixture to save space and eliminate the uniformity issues of multiple emitters. Mega Zenigata LEDs deliver high efficacy (high performance modules exceed 100 lm/W) and typically restrict thermal sag to less than 10%.

Sharp's new 50W – 80W Mega Zenigata LEDs provide up to 400W of incandescent equivalent light, and expand the range of luminous flux to more than 6000 lm. The new LEDs maintain the line's compact package dimensions (20 mm × 24 mm) to eliminate unnecessary product redesign.

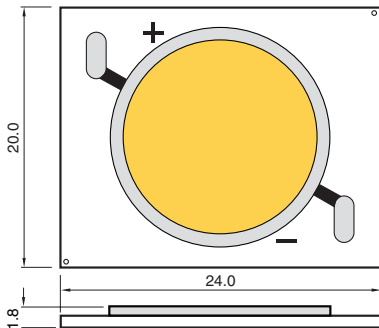

NOTE: Dimensions: mm
Refer to Specifications for full dimensional information

MEGA ZENIGATA

Type	CRI Ra		Part No.	CCT (K)	Current (mA)	Voltage (V)	Luminous Flux (lm)	Efficacy (lm/W)	
	Min.	Typ.							
50W - 80W Normal CRI Rjc = 0.9 K/W	80	82	GW5DLE65MR5	6200	1500	53.25	6832	85.5	
				950	50	4880	102.7		
			GW5DLE50MR5	4900	1500	53.25	6832	85.5	
				950	50	4880	102.7		
			GW5DLE40MR5	4000	1500	53.25	6678	83.6	
				950	50	4770	100.4		
		83	GW5DME35MR5	3500	1500	53.25	6412	80.3	
				950	50	4580	96.4		
			GW5DME30MR5	3000	1500	53.25	6202	77.6	
				950	50	4430	93.3		
			82	GW5DME27MR5	2700	1500	53.25	6020	75.4
					950	50	4300	90.5	
50W - 80W High CRI Rjc = 0.9 K/W	90	90	GW5DGE65MR5	6200	1500	53.25	5460	68.4	
				950	50	3900	82.1		
			GW5DGE50MR5	4900	1500	53.25	5460	68.4	
				950	50	3900	82.1		
		92	GW5DGE40MR5	4000	1500	53.25	5390	67.5	
				950	50	3850	81.1		
		93	GW5DGE35MR5	3500	1500	53.25	5236	65.6	
				950	50	3740	78.7		
			GW5DGE30MR5	3000	1500	53.25	5138	64.3	
				950	50	3670	77.3		
			82	GW5DGE27MR5	2700	1500	53.25	5026	62.9
					950	50	3590	75.6	

Type	CRI Ra		Part No.	CCT (K)	Current (mA)	Voltage (V)	Luminous Flux (lm)	Efficacy (lm/W)
	Min.	Typ.						
25W - 40W Normal CRI Rjc = 2.0 K/W	80	82	GW5DLC65M04	6500	1050	38.5	3640	90.0
					700	37	2600	100.4
			GW5DLC50M04	5000	1050	38.5	3640	90.0
					700	37	2600	100.4
			GW5DLC40M04	4000	1050	38.5	3570	88.3
					700	37	2550	98.5
		83	GW5DMC35M04	3500	1050	38.5	3430	84.8
					700	37	2450	94.6
			GW5DMC30M04	3000	1050	38.5	3318	82.1
					700	37	2370	91.5
			GW5DMC27M04	2700	1050	38.5	3220	79.7
					700	37	2300	88.8
25W - 40W High CRI Rjc = 2.0 K/W	90	90	GW5DGC65M04	6500	1050	38.5	2912	72.0
					700	37	2080	80.3
			GW5DGC50M04	5000	1050	38.5	2912	72.0
					700	37	2080	80.3
		92	GW5DGC40M04	4000	1050	38.5	2870	71.0
					700	37	2050	79.2
		93	GW5DGC35M04	3500	1050	38.5	2758	68.2
					700	37	1970	76.1
			GW5DGC30M04	3000	1050	38.5	2730	67.5
					700	37	1950	75.3
			GW5DGC27M04	2700	1050	38.5	2674	66.1
					700	37	1910	73.7

Type	CRI Ra		Part No.	CCT (K)	Current (mA)	Voltage (V)	Luminous Flux (lm)	Efficacy (lm/W)	
	Min.	Typ.							
15W - 25W Normal CRI R _{jc} = 2.8 K/W	80	82	GW5DLA65M04	6500	700	39	2402	88.0	
				400	37	1550	104.7		
			5000	700	39	2402	88.0		
		83	GW5DLA40M04	4000	700	39	2356	86.3	
				400	37	1520	102.7		
			3500	700	39	2247	82.3		
	80	83	GW5DMA30M04	3000	700	39	2170	79.5	
				400	37	1400	94.6		
			2700	700	39	2092	76.6		
		90	90	GW5DMA27M04	2700	700	39	2092	76.6
					400	37	1350	91.2	
				6500	700	39	1937	71.0	
15W - 25W High CRI R _{jc} = 2.8 K/W	90		90	GW5DGA65M04	6500	700	39	1937	71.0
					400	37	1250	84.5	
				5000	700	39	1937	71.0	
		92	GW5DGA50M04	4000	700	39	1906	69.8	
				400	37	1230	83.1		
			3500	700	39	1860	68.1		
	93	GW5DGA40M04	4000	700	39	1906	69.8		
			400	37	1230	83.1			
		3000	700	39	1813	66.4			
90	GW5DGA30M04	3000	700	39	1813	66.4			
		400	37	1170	79.1				
	2700	700	39	1782	65.3				
90	GW5DGA27M04	2700	700	39	1782	65.3			
		400	37	1150	77.7				

The Mini Zenigata COB

Our refreshed line of “2nd Generation” Mini Zenigata COB LEDs offers a luminous efficacy of up to 106 lm/W in standard operation, and a luminous flux between 300 and 1,672 lm. The new 15W module features a circular Light Emitting Surface (LES) of 8 mm to simplify lens and reflector design. All LEDs in the Mini Zenigata family provide a uniform package size of 15 × 12 × 1.6 mm.

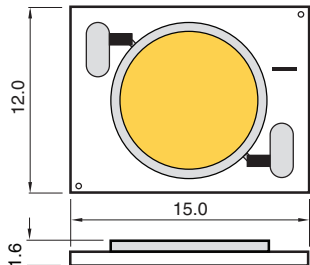

NOTE: Dimensions: mm

Refer to Specifications for full dimensional information

MINI ZENIGATA

Type	CRI Ra		Part No.	CCT (K)	Current (mA)	Voltage (V)	Luminous flux (lm)	Efficacy (lm/W)
	Min.	Typ.						
10W - 15W Normal CRI Rjc = 2.5 K/W	80	83	GW5BMR50K05	5000	440	42.5	1672	89.4
					400	39	1520	97.4
			GW5BMR40K05	4000	440	42.5	1672	89.4
					400	39	1520	97.4
			GW5BMR30K05	3000	440	42.5	1540	82.4
					400	39	1400	89.7
			GW5BMR27K05	2700	440	42.5	1485	79.4
					400	39	1350	86.5
10W - 15W High CRI Rjc = 2.5 K/W	90	93	GW5BGR50K05	5000	440	42.5	1375	73.5
					400	39	1250	80.1
			GW5BGR40K05	4000	440	42.5	1353	72.4
					400	39	1230	78.8
			GW5BGR30K05	3000	440	42.5	1287	68.8
					400	39	1170	75.0
			GW5BGR27K05	2700	440	42.5	1265	67.6
					400	39	1150	73.7

Type	CRI Ra		Part No.	CCT (K)	Current (mA)	Voltage (V)	Luminous flux (lm)	Efficacy (lm/W)
	Min.	Typ.						
10W - 15W Normal CRI Rjc = 5 K/W	80	82	GW5BMJ65K04	6500	800	18.7	1368	91.4
					480	17.7	900	105.9
			GW5BMJ50K04	5000	800	18.7	1368	91.4
					480	17.7	900	105.9
			GW5BMJ40K04	4000	800	18.7	1338	89.4
					480	17.7	880	103.6
	GW5BMJ35K04	3500	800	18.7	1307	87.4		
			480	17.7	860	101.2		
	GW5BMJ30K04	3000	800	18.7	1277	85.3		
			480	17.7	840	98.9		
	GW5BMJ27K04	2700	800	18.7	1216	81.3		
			480	17.7	800	94.2		
7W - 10W Normal CRI Rjc = 7.6 K/W	80	82	GW5BMF65K04	6500	680	12.5	744	87.5
					520	12.3	620	96.9
			GW5BMF50K04	5000	680	12.5	744	87.5
					520	12.3	620	96.9
			GW5BMF40K04	4000	680	12.5	720	84.7
					520	12.3	600	93.8
	GW5BMF35K04	3500	680	12.5	696	81.9		
			520	12.3	580	90.7		
	GW5BMF30K04	3000	680	12.5	672	79.1		
			520	12.3	560	87.6		
	GW5BMF27K04	2700	680	12.5	636	74.8		
			520	12.3	530	82.9		

Type	CRI Ra		Part No.	CCT (K)	Current (mA)	Voltage (V)	Luminous flux (lm)	Efficacy (lm/W)
	Min.	Typ.						
4W - 5W Normal CRI R _{jc} = 7.6 K/W	80	82	GW5BMC65KG4	6500	500	9.4	414	88.1
					400	9.2	360	97.8
			GW5BMC50KG4	5000	500	9.4	414	88.1
					400	9.2	360	97.8
			GW5BMC40KG4	4000	500	9.4	403	85.6
					400	9.2	350	95.1
			GW5BMC35KG4	3500	500	9.4	391	83.2
					400	9.2	340	92.4
			GW5BMC30KG4	3000	500	9.4	380	80.7
					400	9.2	330	89.7
			GW5BMC27KG4	2700	500	9.4	357	75.9
					400	9.2	310	84.2

The Petite Zenigata COB

Sharp now introduces a new class of COB LEDs, the Petite Zenigata, ranging from 4W – 6W. Normal CRI products deliver between 390 – 550 lumens. Products in the High CRI line deliver between 300 – 395 lumens. They are perfectly suited for applications requiring compact lenses, such as small spot or track lighting fixtures.

The 9.6V product allows a simple “buck” DC-DC converter to be used for MR16 lamps (which normally require 12V), while a higher-voltage 40V part provides a “next generation” alternative to traditional line voltage in GU10 lamps. Petite Zenigata LEDs have a compact package size of 8 mm × 12 mm and a circular Light Emitting Surface (LES) of just 4 mm.

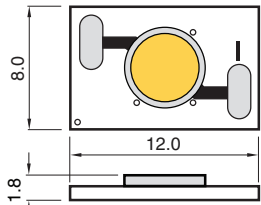

NOTE: Dimensions: mm

Refer to Specifications for full dimensional information

PETITE ZENIGATA

Type	CRI Ra		Part No.	CCT (K)	Current (mA)	Voltage (V)	Luminous flux (lm)	Efficacy (lm/W)	
	Min.	Typ.							
SMQ 6W Class Normal CRI R _{jc} = 11.5 K/W	80	82	GW5SMQ50P05	4850	160	40.9	495	75.6	
					140	40	450	80.4	
			GW5SMQ40P05	3950	160	40.9	495	75.6	
					140	40	450	80.4	
			GW5SMQ35P05	3400	160	40.9	462	70.6	
					140	40	420	75.0	
	GW5SMQ30P05	3000	160	40.9	462	70.6			
			140	40	420	75.0			
	GW5SMQ27P05	2730	160	40.9	429	65.6			
			140	40	390	69.6			
	SMD 5W Class Normal CRI R _{jc} = 11.5 K/W	80	82	GW5SMD50P05	4850	560	9.75	469	85.8
						500	9.6	430	89.6
GW5SMD40P05				3950	560	9.75	469	85.8	
					500	9.6	430	89.6	
GW5SMD35P05				3400	560	9.75	436	79.9	
					500	9.6	400	83.3	
GW5SMD30P05		3000	560	9.75	436	79.9			
			500	9.6	400	83.3			
GW5SMD27P05		2730	560	9.75	403	73.9			
			500	9.6	370	77.1			

Type	CRI Ra		Part No.	CCT (K)	Current (mA)	Voltage (V)	Luminous flux (lm)	Efficacy (lm/W)
	Min.	Typ.						
SGD 5W Class High CRI Rjc = 11.5 K/W	90	92	GW5SGD50P05	4850	560	9.75	391	71.5
					500	9.6	360	75.0
			GW5SGD40P05	3950	560	9.75	391	71.5
					500	9.6	360	75.0
			GW5SGD35P05	3400	560	9.75	358	65.6
					500	9.6	330	68.8
	GW5SGD30P05	3000	560	9.75	358	65.6		
			500	9.6	330	68.8		
	80	82	GW5SGD27P05	2730	560	9.75	326	59.6
					500	9.6	300	62.5
			GW5SMC500P05	4850	460	9.95	352	76.9
					400	9.8	320	81.6
GW5SMC40P05			3950	460	9.95	352	76.9	
				400	9.8	320	81.6	
GW5SMC35P05	3400	460	9.95	330	72.1			
		400	9.8	300	76.5			
SMC 4W Class Normal CRI Rjc = 16 K/W	80	GW5SMC30P05	3000	460	9.95	330	72.1	
				400	9.8	300	76.5	
		GW5SMC27P05	2730	480	9.95	308	64.5	
				400	9.8	280	71.4	

The Double Dome

Sharp's specialty Double Dome LED family provides a high-intensity white LED option for area and strip lighting solutions where linear lighting is desired. Its moderate light output cuts down on potential glare compared to higher-wattage LEDs. A small (2.8 mm × 2.8 mm × 1.9 mm) surface-mountable footprint provides ease of installation.

Sharp's new one die Double Dome is ideal for applications requiring more moderate light output for even greater glare avoidance. It also offers a unique, energy-saving option for fixtures that place a series of LEDs in a line (i.e., LED "tube-style" lighting).

The 0.3W – 0.5W Double Dome products integrate two LED die in each package, and are designed for intermediate applications that require an elegant lighting solution. The 0.8W Double Dome integrates three LED die to achieve higher lumen output for maximum brightness.

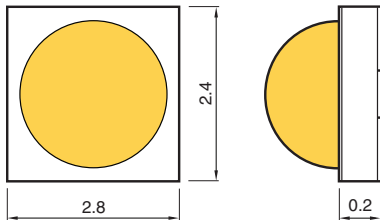

NOTE: Dimensions: mm
Refer to Specifications for full dimensional information

DOUBLE DOME

Type	CRI Ra		Part No.	CCT (K)	Current (mA)	Voltage (V)	Luminous flux (lm)	Efficacy (lm/W)
	Min.	Typ.						
Double Dome 0.5W (3 dice) R _{jc} = 25 K/W	80	83	GM2BB65QK0C	6500	220	3.07	68.5	101
				150	2.95	50	113	
			GM2BB57QK0C	5700	220	3.07	71	105
				150	2.95	52	118	
			GM2BB50QK0C	5000	220	3.07	72.5	107
				150	2.95	53	120	
			GM2BB45QK0C	4500	220	3.07	70	104
				150	2.95	51	115	
			GM2BB40QK0C	4000	220	3.07	68.5	101
				150	2.95	50	113	
			GM2BB35QK0C	3500	220	3.07	66	98
				150	2.95	48	108	
			GM2BB30QK0C	3000	220	3.07	63	93
				150	2.95	46	104	
			GM2BB27QK0C	2700	220	3.07	60.5	90
				150	2.95	44	99	

Type	CRI Ra		Part No.	CCT (K)	Current (mA)	Voltage (V)	Luminous flux (lm)	Efficacy (lm/W)
	Min.	Typ.						
Double Dome 0.3W (2 dice) R _{jc} = 33 K/W	80	83	GM2BB65QKAC	6500	160	3.07	50.3	102
					100	2.95	33.5	114
					80	2.90	27.5	119
			GM2BB57QKAC	5700	160	3.07	52.5	107
					100	2.95	35.0	119
					80	2.90	29.0	125
			GM2BB50QKAC	5000	160	3.07	53.3	108
					100	2.95	35.5	120
					80	2.90	29.5	127
			GM2BB45QKAC	4500	160	3.07	51.8	105
					100	2.95	34.5	117
					80	2.90	28.5	123
			GM2BB40QKAC	4000	160	3.07	50.3	102
					100	2.95	33.5	114
					80	2.90	27.5	119
			GM2BB35QKAC	3500	160	3.07	48.8	99
					100	2.95	32.5	110
					80	2.90	27.0	116
			GM2BB30QKAC	3000	160	3.07	46.5	95
					100	2.95	31.0	105
					80	2.90	25.5	110
			GM2BB27QKAC	2700	160	3.07	44.3	90
					100	2.95	29.5	100
					80	2.90	24.5	106

Type	CRI Ra		Part No.	CCT (K)	Current (mA)	Voltage (V)	Luminous flux (lm)	Efficacy (lm/W)
	Min.	Typ.						
Double Dome 0.2W (1 die) Rjc = 65 K/W	80	83	GM2BB65QK1C	6500	100	3.10	31.5	102
					70	3.04	23.1	109
					50	2.95	17.5	119
			GM2BB57QK1C	5700	100	3.10	33.3	107
					70	3.04	24.5	115
					50	2.95	18.5	125
			GM2BB50QK1C	5000	100	3.10	33.3	107
					70	3.04	24.5	115
					50	2.95	18.5	125
			GM2BB45QK1C	4500	100	3.10	32.0	103
					70	3.04	23.5	110
					50	2.95	17.8	121
			GM2BB40QK1C	4000	100	3.10	31.5	102
					70	3.04	23.1	109
					50	2.95	17.5	119
			GM2BB35QK1C	3500	100	3.10	30.2	98
					70	3.04	22.2	104
					50	2.95	16.8	114
			GM2BB30QK1C	3000	100	3.10	29.0	93
					70	3.04	21.3	100
					50	2.95	16.1	109
			GM2BB27QK1C	2700	100	3.10	27.7	89
					70	3.04	20.4	96
					50	2.95	15.4	104



Support

Sharp makes 40 years of LED know-how available to you when you need it most. Our domestic support footprint is filled with experts located in your region who can help save you valuable time in the lab and get to market more quickly.

Have questions? Sharp answers.

Learn More

Contact your local Sharp representative or Distributor for more information or product samples – or visit www.SharpLEDs.com. Our Resources page will lead you to White Papers, Application Notes, Podcasts, Product Specifications, and information about third party support for reflectors, lenses, and holders.

A Brighter Environmental Outlook

The benefits of LED lighting not only brighten your design; they brighten our world. LEDs are free of hazardous substances such as mercury (Hg). They convert energy to visible light much more efficiently than traditional lighting sources. Plus, an increased operating life (Sharp's modules typically exceed 50k hours of operation, versus a typical 10k hours for a compact fluorescent or 2k hours for an incandescent bulb) means a significantly longer time before LEDs require replacement with new modules.



WWW.SHARPLEDS.COM

HEADQUARTERS

5700 NW Pacific Rim Blvd.
Camas, WA 98607, U.S.A.
Phone: (1) 360-834-8700
Fax: (1) 360-834-8903
www.sharpsma.com

WESTERN REGION

1980 Zanker Road
San Jose, CA 95112
Phone: (1) 408-436-4900
Fax: (1) 408-436-0924

EASTERN REGION

200 Wheeler Rd.
Burlington, MA 01803
Phone: (1) 781-270-7979
Fax: (1) 781-229-9117

8000 Regency Parkway, Suite 280
Cary, NC 27518
Phone: (1) 919-460-0695
Fax: (1) 919-460-0795

85 W. Algonquin Road, Suite 280
Arlington Heights, IL 60005
Phone: (1) 847-258-2750
Fax: (1) 847-439-2479

3001 West Big Beaver Road, Ste 722
Troy, MI 48084
Phone: (1) 248-458-1527
Fax: (1) 248-458-6255